

Schneider **ADVANCED ELEMENTS EDITION**

Montage-Anleitung

Instructions de montage

Assembling instructions

Typ

AEE1 60/1/TW

AEE1 60/2/TW

AEE1 80/2/TW

AEE1 100/2/TW

AEE1 120/2/TW

AEE1 140/3/GT/TW

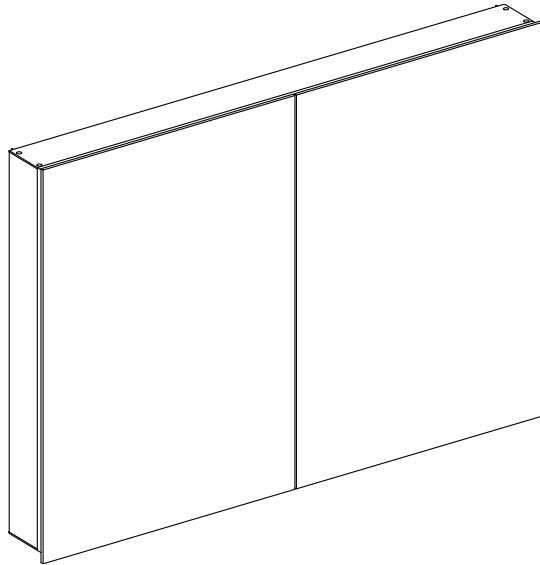

Technische Daten / Caractéristiques techniques/ Technical data

Nennspannung / Tension nominale / Nominal voltage	230 V ~
Betriebsspannung / Tension de service / Operating voltage	24 V ===
Netzfrequenz / Fréquence du réseau/ Mains frequency	50 Hz
Lichtfarbe / Couleur de la lumière / Light colour	2000-6500 K
Schutzart / Type de protection / Protection type	IP 44
Schutzklasse / Classe de protection/ Protection class	I
Steckertyp Steckdose Schweiz / Type de fiche prise Suisse / Plug type socket Switzerland	SEV T13
Steckertyp Steckdose Europa / Type de fiche prise Europe / Plug type socket Europe	CEE 7/3 (Schuko)
Steckertyp Steckdose Grossbritannien / Type de fiche prise Grande-Bretagne / Plug type socket Great Britain	BS 4573 (shaver socket)
Netzspannung Steckdose(n) / Tension du réseau prise(s) électrique / Mains voltage socket(s) outlet	230 V ~
Steckdose(n) I _{max} / Prise(s) I _{max} / socket(s) I _{max}	9 A / 2070 W
Bemessungsstrom / Courant nominal / Nominal current	10 A
Betriebsfrequenz Funk / Fréquence de fonctionnement radio / Operating frequency radio	2400 - 2483, 5 MHz
Maximale Sendeleistung Funk / Puissance d'émission maximale radio / Maximum transmission power radio	0 dBm
Energieeffizienzklasse Lichtquellen / Classe d'efficacité énergétique sources lumineuses / Energy efficiency class light sources	C
Batterietyp / Type de batterie / Battery type	CR2032

Lieferumfang / Contenu de la livraison / Scope of delivery

- Spiegelschrank / Armoire-miroir / Mirror cabinet
- Aufhängeschiene / Rail de suspension / Suspension rail
- Schraubenset / Jeu de vis / Set of screws
- Kosmetikspiegel / Miroir cosmétique / Vanity mirror
- Glastablare / Tablettes en verre / Glass shelves:

2 Stk/pcs	(50/1, 60/1, 80/2)
4 Stk/pcs	(120/2,130/2)
6 Stk/pcs	(150/3, 180/3)

Schneider **ADVANCED ELEMENTS** EDITION



Arbeiten an den elektrischen Anlagen dürfen nur von autorisierten Fachleuten nach den örtlichen Vorschriften ausgeführt werden. Für nicht fachgerechte Installation wird jegliche Haftung abgelehnt.

Les travaux à l'installation électrique ne doivent être effectués que par des spécialistes autorisés selon les prescriptions locales. Si l'installation n'est pas faite par un expert nous déclinons toute responsabilité.

Electric installation work may only be carried out by approved specialists according to the local regulations. Liability will only be accepted by us when our products are installed by qualified engineers.



Räume mit Badewanne oder Dusche müssen mit einer FI-Schutzeinrichtung (RCD) I $\Delta n = 30$ mA gesichert sein. Bereich 2 mindestens Schutzart IP X4. Bereich 2 keine Steckdosen.

Locaux avec baignoire ou douche doivent être protégés par un dispositif de protection FI (RCD) I $\Delta n = 30$ mA. Volume 2 min. degré de protection IP X4. Volume 2 des prises électriques ne sont pas permis.

Rooms with bath or shower have to be protected with residual-current-operated protective device FI (RCD) I $\Delta n = 30$ mA. Volume 2 min. protection IP X4. Volume 2 no socket admitted.

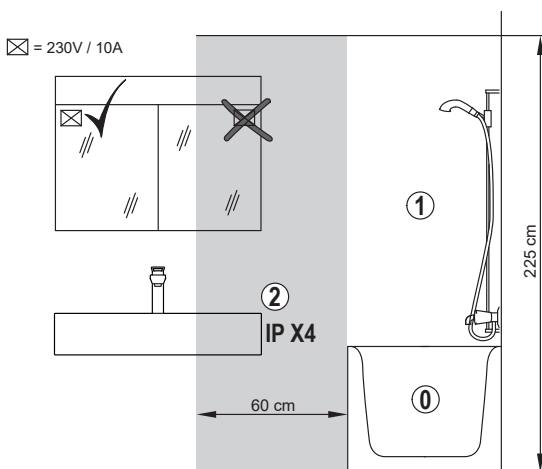

SEV NIN 2015 1000 - 7.01



VDE 0100 - 701



BS 7671 - 601



NEN 1010



Werfen Sie Ihr Produkt, wenn es ausgedient hat, im Interesse des Umweltschutzes nicht in den Hausmüll, sondern führen Sie es einer fachgerechten Entsorgung zu.



Dans l'intérêt de la protection de l'environnement, ne jetez pas votre produit avec les ordures ménagères lorsqu'il est hors d'usage. Le mettre au rebut de manière appropriée.

In the interests of environmental protection, do not dispose of your product with household waste when it has reached the end of its service life, but dispose of it properly



Eignet sich nur für Innenräume.
Uniquement montage intérieur.
Indoor installation only.

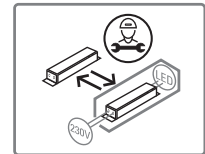
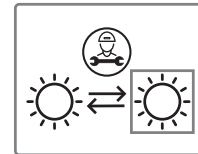

Die Lichtquellen und elektronischen Bauteile sind gemäss Artikel 4 der EU-Verordnung 2019/2020 durch den Hersteller oder eine Fachperson auswechselbar.

Les sources lumineuses et les composants électroniques sont remplaçables par le fabricant ou par une personne qualifiée, conformément à l'article 4 du règlement EU 2019/2020.

The light sources and electronic components are replaceable by the manufacturer, or by a qualified person in accordance with Article 4 of EU Regulation 2019/2020.



Dieses Produkt erfüllt die Anforderungen der geltenden europäischen und nationalen Richtlinien. Die Konformität wurde nachgewiesen. Entsprechende Erklärungen und Unterlagen sind beim Hersteller hinterlegt.

Ce produit répond aux exigences des directives européennes et nationales en vigueur. La conformité a été prouvée. Les déclarations et documents correspondants sont déposés auprès du fabricant.

This product fulfils the requirements of the applicable European and national directives. Conformity has been verified. Corresponding declarations and documents are available from the manufacturer.

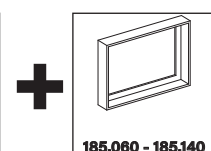
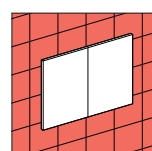
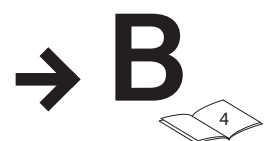
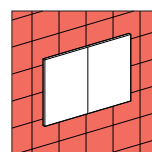
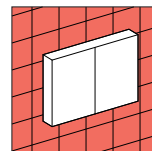

185.060 - 185.140

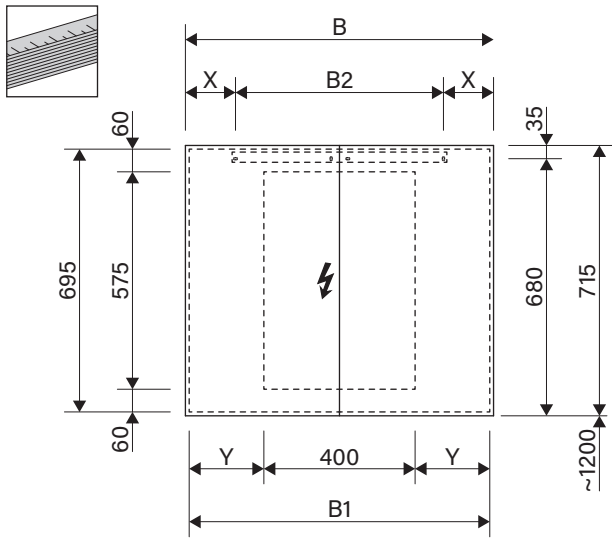

B	B1	B2
615	595	350
815	795	650
1015	995	650
1215	1195	950
1415	1395	950

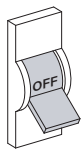
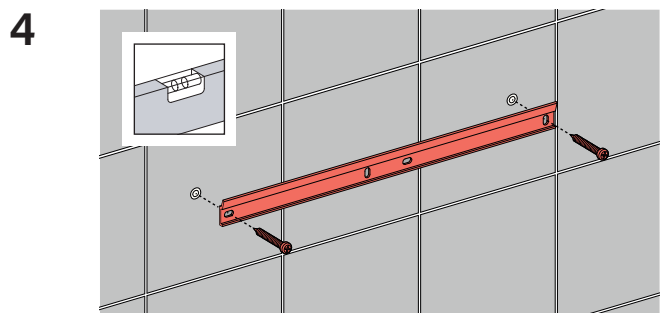
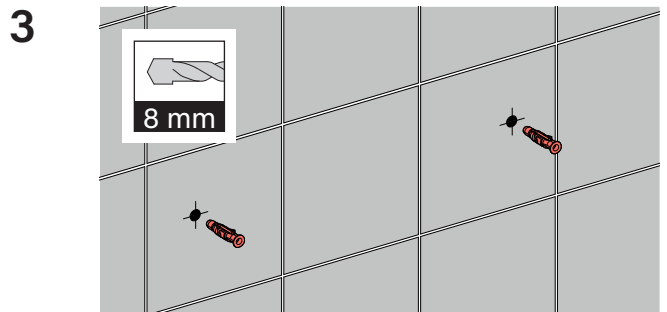
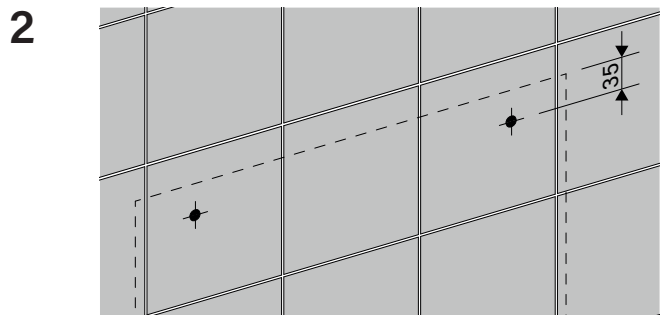
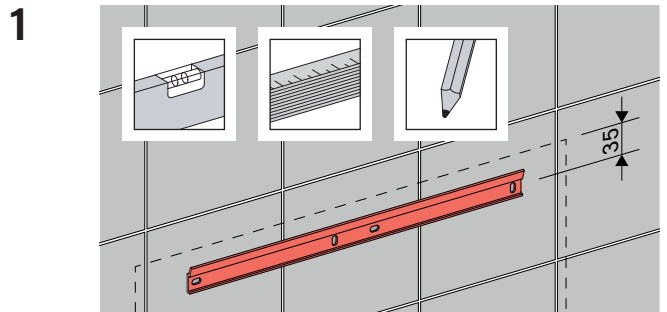
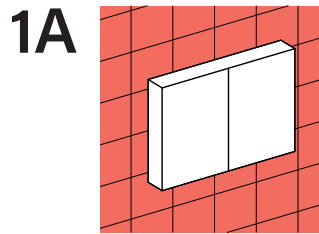
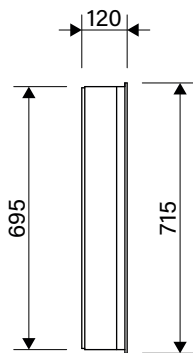

Vor dem Beginn vom Netz trennen.

Au début séparer du réseau.

Turn off electricity before beginning.



Spiegeltüren vor Einbau entfernen

Démonter les portes miroirs avant la pose.

Remove mirror doors before installation.

5

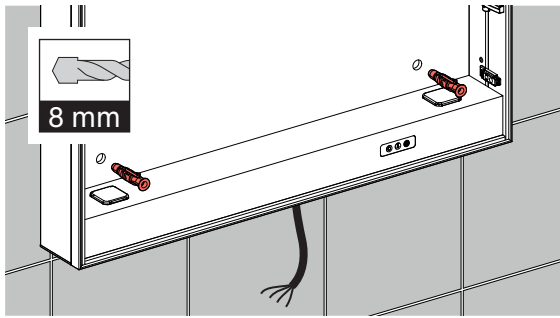

6

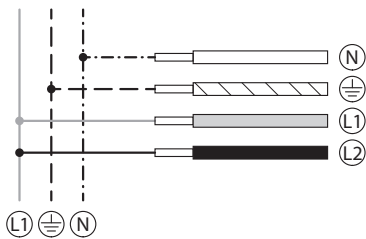
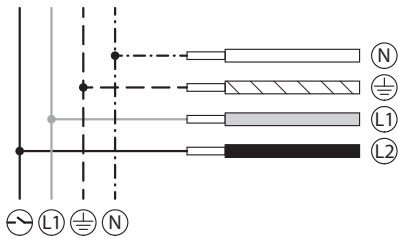

7

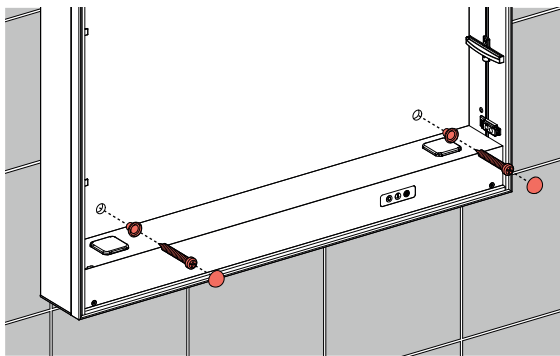

1B

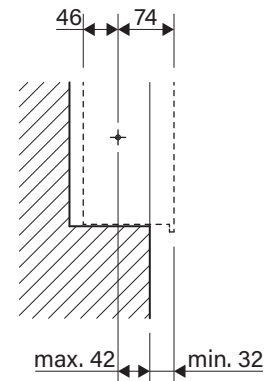
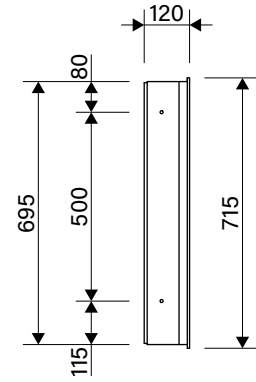
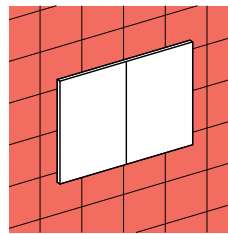

Nischengröße X x Y und Befestigung Spiegelschrank sind bauseits zu bestimmen.

La taille de la niche X x Y et la fixation de l'armoire-miroir doivent être déterminées par le client.

The recess dimensions X by Y and the fixing system for the mirrored cabinet will need to be determined on site.

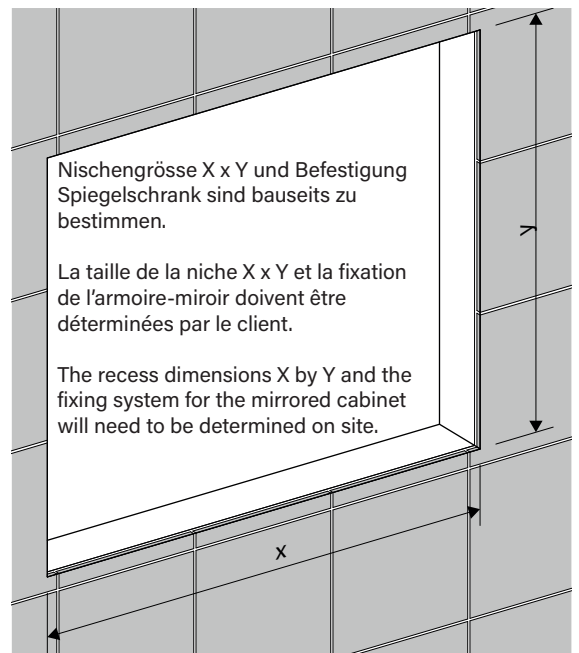

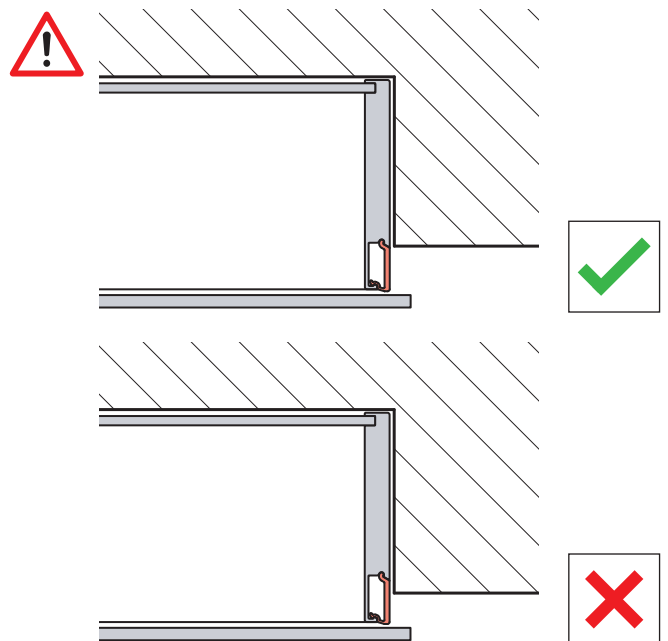
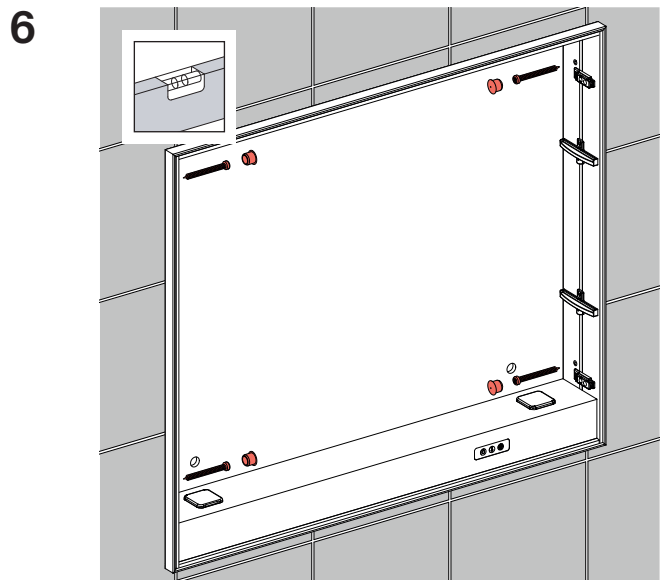
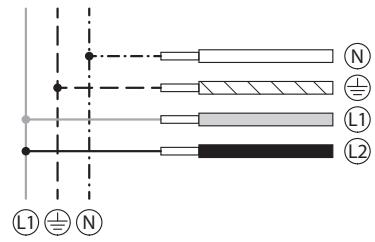
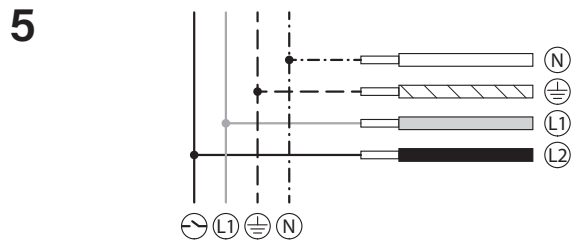
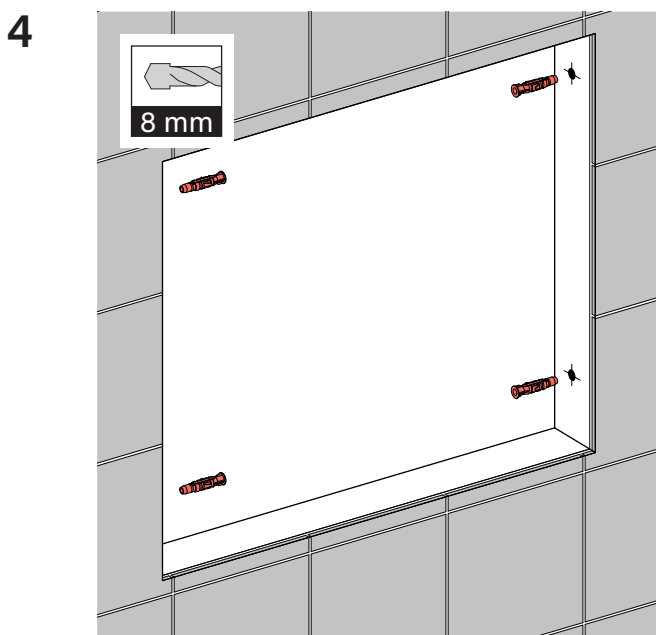
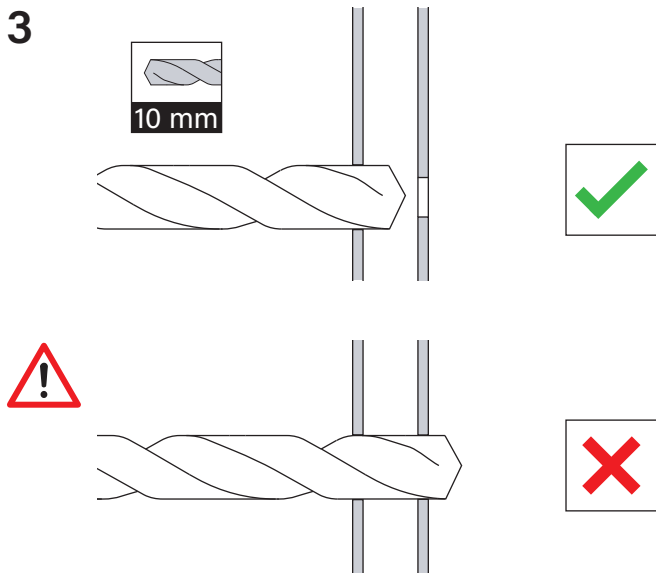
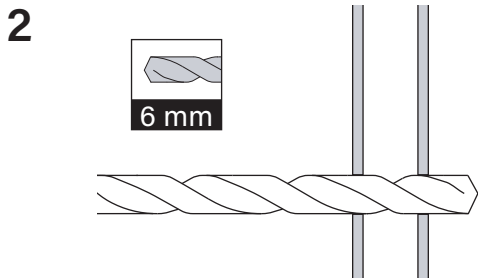
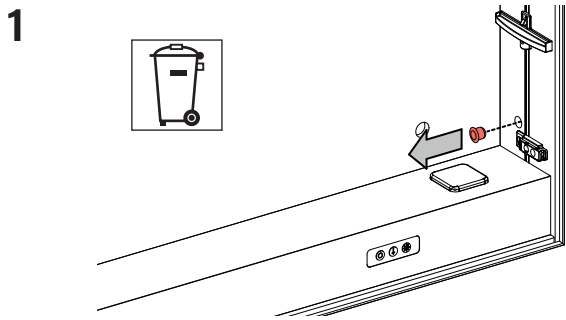

1C

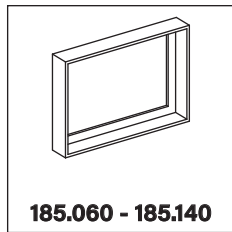
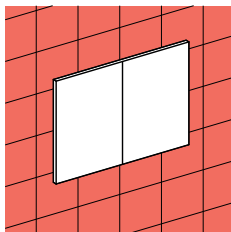

185.060 - 185.140

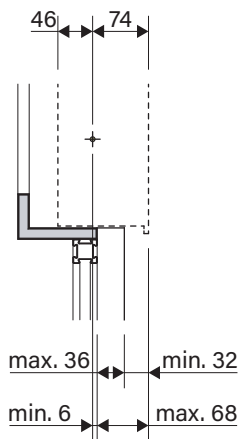
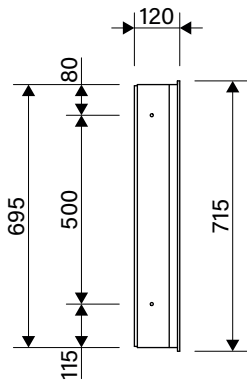

1

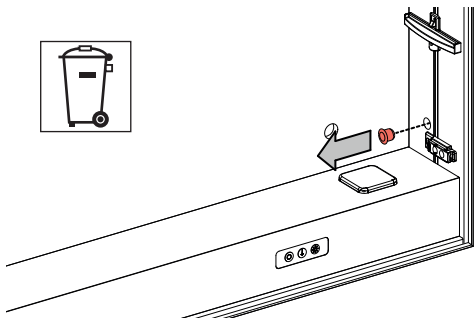

2

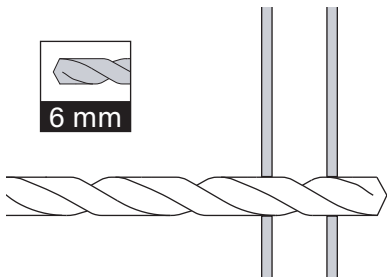

3

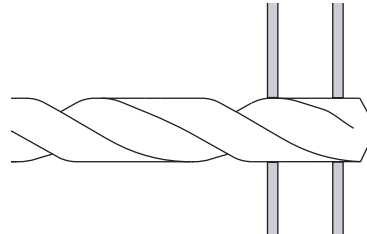
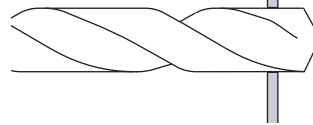

4

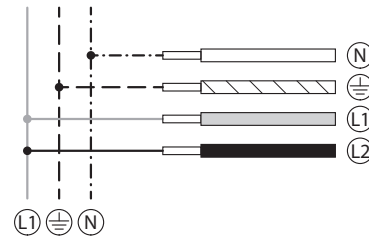
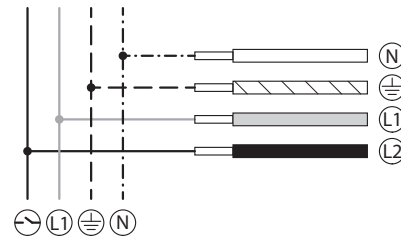

5

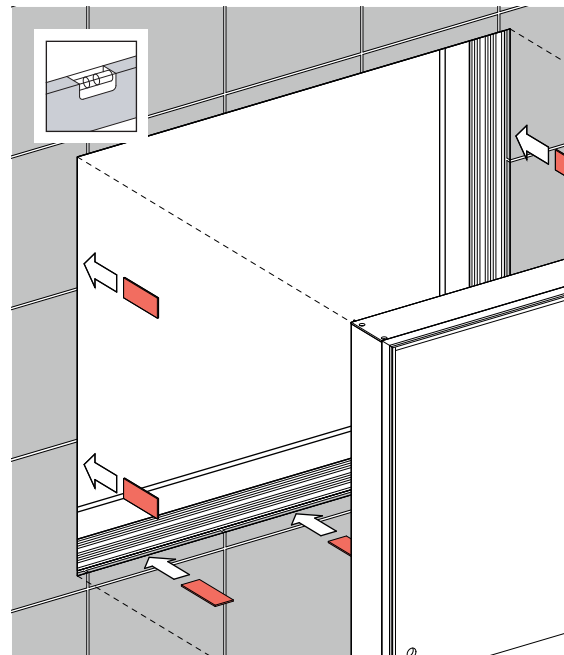

6

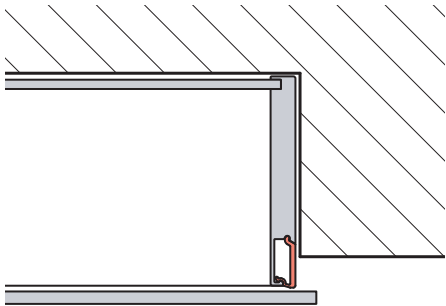
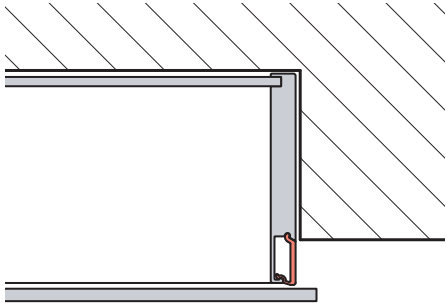
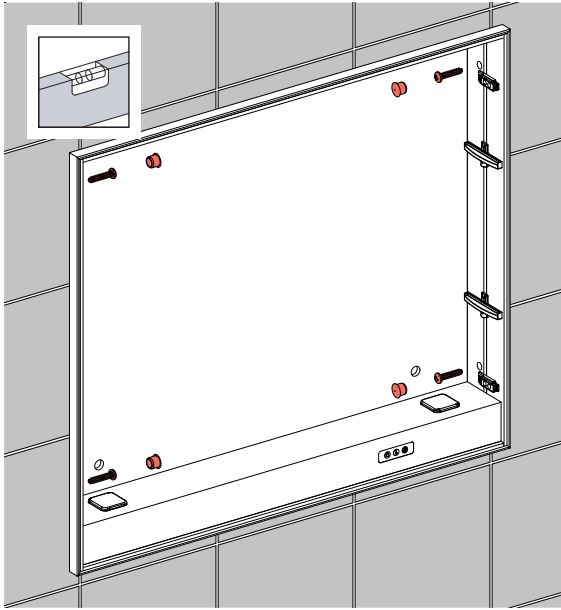

2 Einstellungen Calibrage Adjustments

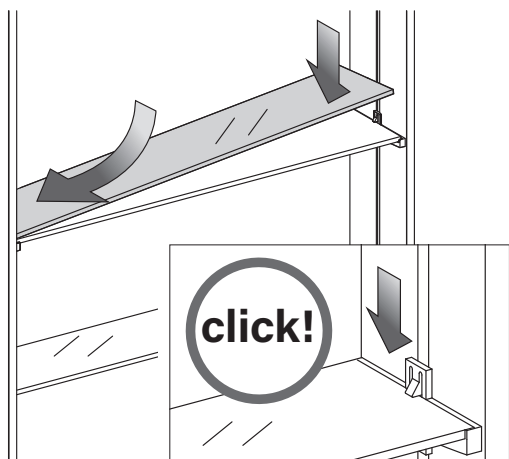
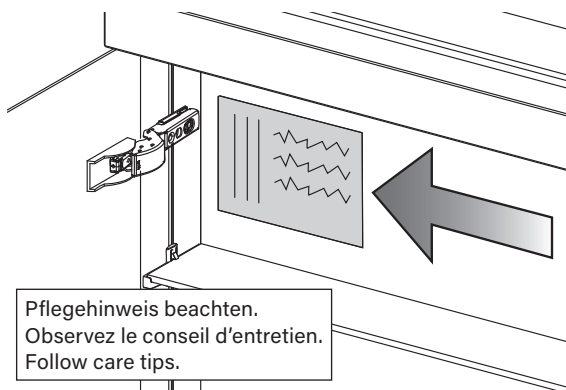
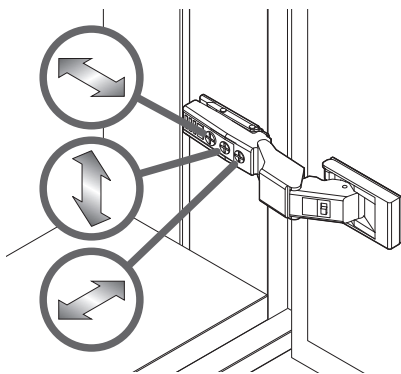
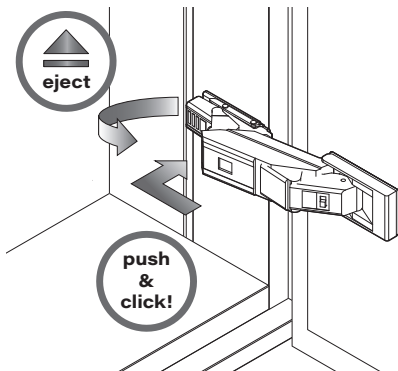

Lichtquelle aktiv / inaktiv
Illumination active / inactive
Lighting active / inactive

Helligkeit Dimmen + / - (drücken & halten)
Brillance varier l'intensité lumineuse + / - (pousser & tenir)
Brightness Dim + / - (press & hold)

Lichttemperatur 2000 - 6500 K (drücken & halten)
Température de lumière 2000 - 6500 K (pousser & tenir)
Light temperature 2000 - 6500 K (press & hold)

694.434 05.24/A Änderungen vorbehalten / Sous réserve de modifications / Alterations are reserved

W. Schneider + Co. AG
Büntenrietstrasse 12
CH-8890 Flums
www.wschneider.com